

## SW-E8 Series:

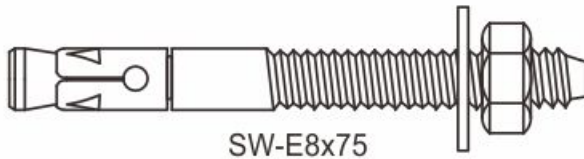

SW-E8x75



Material: S.S. 304 / S.S. 316

**EOTA** (Cracked Concrete Tested  
ETAG-001-Annex-A)

Tested By:

**MaterialLab**
**Tested as per BS 5080**

## Installation Parameters

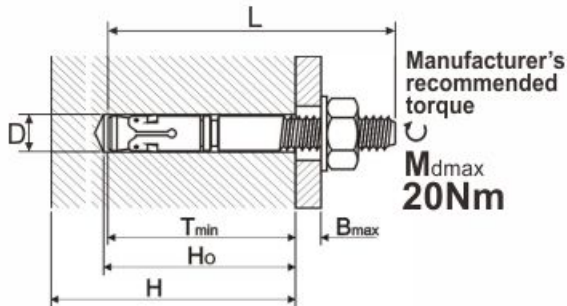

## Installation Parameters Table

Item	Model	SW-E8x75	SW-E8x100
H (mm) Min, Concrete thickness.		100	100
D (mm) Drill hole diameter		8	8
H <sub>o</sub> (mm) Manufacturer's recommended drill hole depth		60	60
T <sub>min</sub> (mm) Manufacturer's recommended embedment depth		50	50
B <sub>max</sub> (mm) Max. Thickness of installation material		10	23
L (mm) Anchor total length		75	100
*Variable length = Tailor made longer Si			
<b>M<sub>dmax</sub></b>	<b>Manufacturer's recommended torque</b>	<b>20Nm</b>	<b>20Nm</b>

## Range of application:

Item to be application	
<ul style="list-style-type: none"> <li>○ Steel channel</li> <li>○ Steel frame</li> <li>○ Metalwork</li> <li>○ Wooden structure</li> <li>○ Mechanical equipment</li> <li>○ Highway fences &amp; dividers</li> <li>○ Electronic equipment</li> </ul>	<ul style="list-style-type: none"> <li>○ Aluminum windows and louvers</li> <li>○ Cladding works</li> <li>○ Stone facades</li> <li>○ Curtain wall</li> <li>○ Handrail</li> <li>○ Suspending objects</li> </ul>
Characteristics	
<ul style="list-style-type: none"> <li>○ Corrosion resistant</li> <li>○ Quick acting</li> <li>○ Small edge distance &amp; separation of anchor</li> </ul>	<ul style="list-style-type: none"> <li>○ Stabilize on moving objects</li> <li>○ Releasable</li> <li>○ Mechanical fixing</li> </ul>
Base Material	
<ul style="list-style-type: none"> <li>○ Non-cracked concrete</li> <li>○ Cracked concrete</li> </ul>	

## Installation Procedure

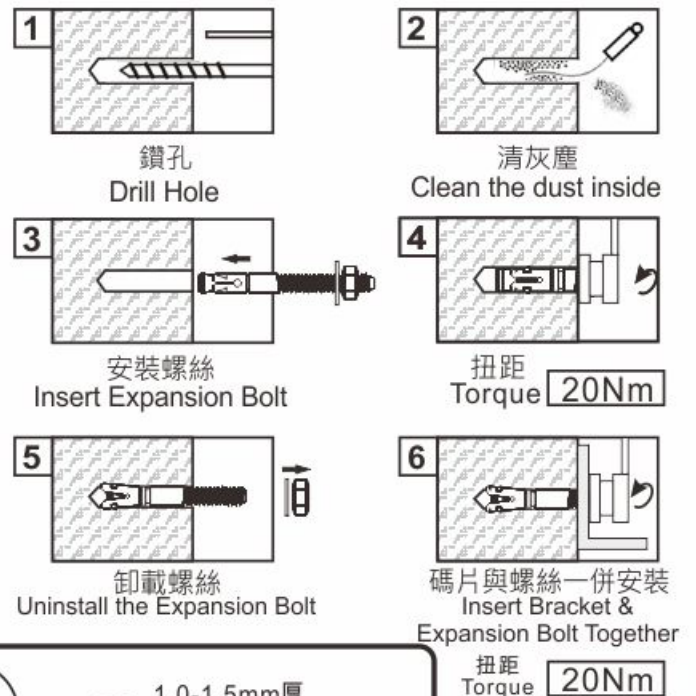



2mm厚



20mm

1.0-1.5mm厚



15-16mm

SUNWAY膨脹螺絲  
 外用之不銹鋼介子  
 更強抓著力

一般市面膨脹螺絲外  
 用之不銹鋼介子

SUNWAY Stainless Steel Washer of Expansion Bolt can secure the bolt better than the general Stainless Steel Washer of Expansion Bolt .

如需更多資料或有任何疑問，請與我們聯絡。

For more information, please contact us.

Tel : (852) 2552 5210 , E-mail : sunway@sunwayltd.com.hk

Fax: (852) 2814 0776 , Website : http://www.sunwaymetal.com/